

SPECIFICATIONS

BORE	30.4mm
STROKE	25.8mm
DISPLACEMENT	18.73cc
WEIGHT	730g
RPM	2,000 ~ 13,000rpm

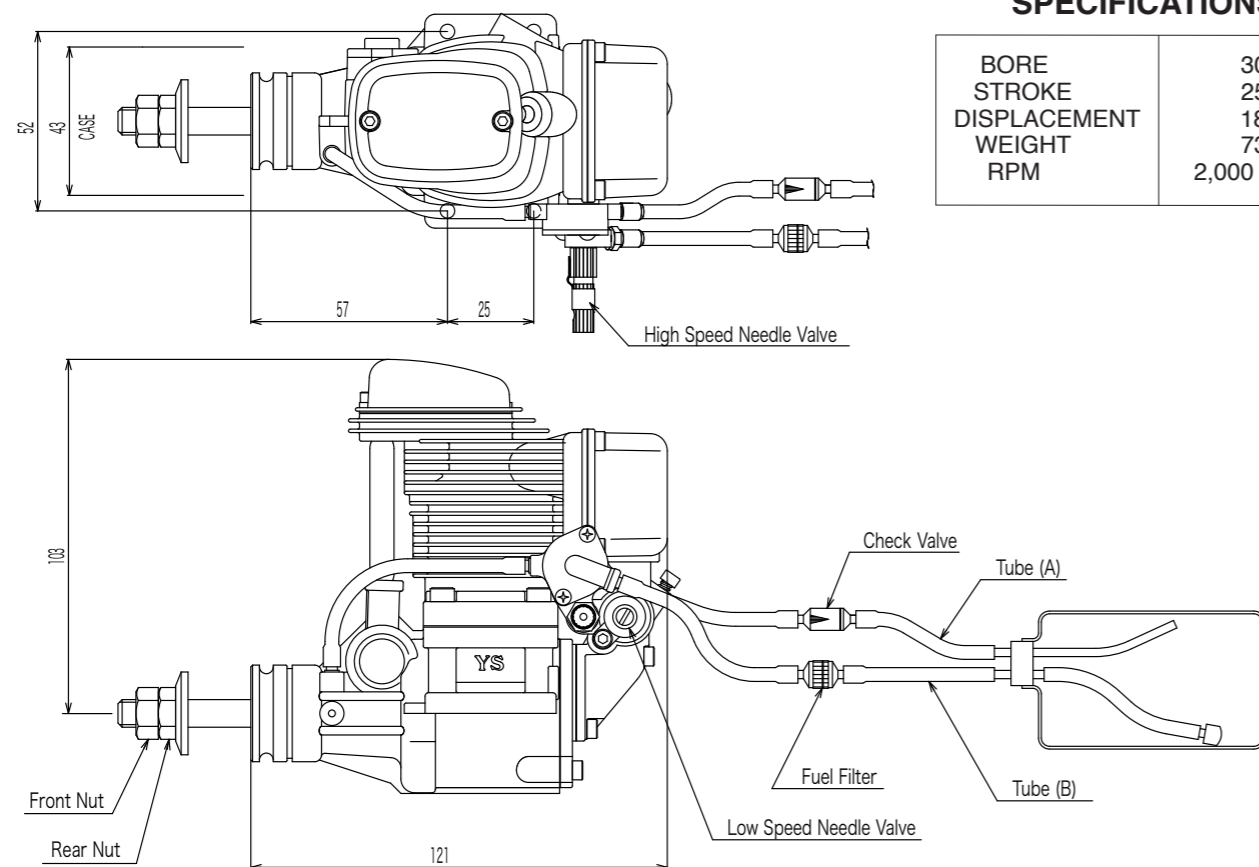

FIG.1

FEATURES

The FZ115WS is the most powerful 110 class four cycle engine available. This engine offers many exclusive features that have been proven on other YS engines.

Supercharged system with simplified structure to keep weight to a minimum while still retaining maximum efficiency.

Air chamber that uses crankcase pressure coupled with a double throttle valve system which allows a bigger charge of fuel and air mixture to enter the intake valve for more power.

Fuel injection system for superior throttle response. This system is unaffected by tank position or by the attitude of the model.

GIOW PLUG

Select the most appropriate glow plug from those designed specifically for 4 cycle engines. Glow plug selection greatly affects the maximum engine output and low idle. If RPM's decrease or stop when the booster cord is removed, replace the plug.

We recommend YS #4 (YS4GP) or OS Type F.

INSTALLATION

1. Connect the engine to the tank as shown in FIG.1. Since high pressure is applied to the tank, tighten all connections carefully. Care must be taken to prevent pressure leakage due to undertightening of the check valve or by kinking the fuel lines.
2. Always uses a fuel filter (not included). We recommend the YS filter (YS1195).
3. Match the direction of the check valve arrow to FIG.1, with the arrow facing towards the tank.

PROPELLER INSTALLATION

Due to the high torque of the FZ115S engine, we have equipped it with double locknuts for safety.

1. Mount the propeller and tighten the rear nut. Next, tighten the front nut as shown in FIG.1.
2. Select a good quality propeller that will turn in the 7,000 to 11,000rpm range. We recommend sizes 14x11-12, 15x10-11, 16X8.

START-UP

1. Remove tube(B) from the filter, remove tube(A) from the check valve, then fill the tank.
Caution: If tank is filled or under pressure ,remove tube(A) first, then remove tube(B). Fuel will eject if tube(B) is removed first while the tank is pressurized.
2. Open the needle valve 1 1/2~ 2 from the fully closed position.
3. Open the throttle about 10% from the idle position and slowly turn the propeller ten turns. This primes the system by pressurizing the tank and sending fuel to the carburetor.
4. Pour several drops of fuel into the carburetor.
5. Close the throttle to the idle position and connect the glow plug cord. The engine is now ready for starting.

Do not attempt to start at full throttle, as this is very dangerous.

BREAK-IN

To maximize engine performance and increase durability, please follow this break-in procedure:

1. Use the same size (or slightly smaller) propeller than you intend to use in flying.
2. Use a good quality fuel which contains nitromethane and an oil content of 15-25%. Synthetic or castor oil can be used, or a combination of synthetic and castor. Do not use four cycle fuel due to low oil content.
3. The needle valve should be set so that the engine is running at a rich setting. Run the engine approximately 20 minutes with this setting.
4. Mount the engine to the model and fly ten times with this setting. This concludes the break-in procedure. It is advisable to always use a slightly rich setting to keep the moving parts lubricated, even after the break-in period.

HIGH SPEED ADJUSTMENT

1. Adjustment of high speed is done by the high speed needle valve. When it is turned clockwise, the mixture is leaner. When it is turned counterclockwise, the mixture is richer. A good starting position for the high speed needle valve is 1 1/2 - 2 turns open from fully close position.
2. When the engine is started, open the throttle gradually. Next, find the peak position (highest RPM) by adjusting the needle valve. Then the needle valve should be opened approximately 1/8 of a turn from full RPM to achieve best performance. The engine may stop if the throttle is opened to full immediately after starting. Wait until the engine temperature rises and then open the throttle slowly.
3. For flying, it is advisable to use a slightly richer mixture setting. By using a richer mixture, the engine temperature is maintained and RPM stability improves.

LOW SPEED ADJUSTMENT

This engine is equipped with a low speed needle valve to adjust the mixture from low to mid throttle. This needle valve is located on the side of the throttle barrel opposite the throttle arm (FIG.1).

1. Open the low speed needle to 2 turns from fully closed position.
2. The low speed needle valve should be set after the high speed needle valve has been adjusted. Close the throttle gradually to a idle (approximately 2300rpm). Let it idle for 20 to 30 seconds and then slowly advance the throttle. The adjustment is satisfactory at low speed if transition is smooth at this time.
3. If the engine is running rough on idle, the low speed mixture is rich. If the engine starts to speed up and dies on idle or starts to detonate, when advancing the throttle, the mixture is lean. Turn the low speed needle valve clockwise to richen and counterclockwise for a leane mixture (note that the direction of the low speed needle valve is opposite the high speed needle valve). Adjustments to the low speed needle valve should be 1/8 to 1/4 of a turn increment at a time to achieve smooth throttle response.

FIG.2

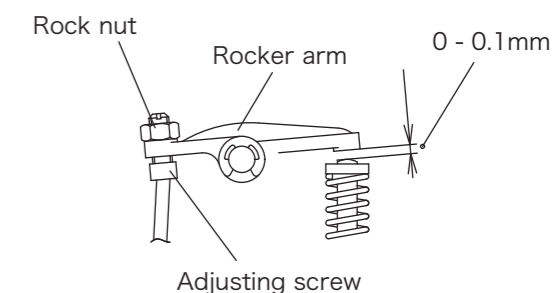

TAPPET CLEARANCE ADJUSTMENT

1. Tappet clearance is factory preset. No adjustment is necessary unit after 1 hour of operation(including break-in period).
2. Clearance adjustment should be done when the engine is cool. When the engine temperature is high, clearance is higher due to thermal expansion.
3. The proper clearance setting should be at 0 - 0.1mm. The adjustment is achieved by loosing the locknut (FIG.2) and turning the adjusting screw. Tighten the locknut after the adjustment is achieved. After the initial 1 hour adjustment, this procedure should be performed after every 2 hours of use.

CAMGEAR TIMING ADJUSTMENT

If for some reason you have to disassemble your engine, please follow these important steps on reassembling the cam gear.

1. Remove the carburetor and backplate assembly. Notice the impression made on the crankshaft counterweight. Position it directly straight down or in line with the case outer seam line.
2. When reinstalling the cam gear, the side with a point mark should be facing the opening of the gear box. Note that it should also be mounted with the point mark located towards the top of the engine just below the cam followers.

IMPORTANT! Silicone rubber is used in many parts of the YS engine. Use only glow fuel or methanol for cleaning. Gasoline and other volatile solutions will damage the silicone if used.

WARRANTY

Strict quality control is implemented by our factory in all phases, from parts manufacturing to final assembly. If performance deteriorates or a part fails due to a manufacturing error, YS will repair or replace the engine at no charge in the period of one year from date of purchase. Warranty does not cover normal maintenance.

Should the engine be modified, incorrectly assembled or abused, there will be a normal charge for parts and labor. The use of four cycle fuel due to the low oil content will also void warranty.

NO.	ITEM NO.	N A M E	QTY
1	YS6405	Crank case	1
	YS6410	Cylinder head assembly	
2	YS6415	Cylinder head	1
3	YS1590	Intake valve	1
4	YS1600	Exhaust valve	1
5	YS0540	Valve spring set	2
6	YS2030	Spring retainer set	2
7	YS2040	Valve spring retainer clips	4
8	YS5415	Cylinder gasket	1
9	YS5420	Head screws	4
10	YS7005	Valve cover	1
11	YS1650	Valve cover gasket	1
12	YS1660	Valve cover screws	2
13	YS1670	Rear air chamber	1
14	YS1680	Air chamber gasket	1
15	YS1690	Air chamber screws	4
16	YS1700	Air chamber O ring	1
17	YS7010	Crankshaft	1
18	YS5430	Crankshaft ring	
19	YS6425	Rear bearing	1
20	YS1050	Front bearing	1
21	YS1730	Front bearing oil seal	1
22	YS4325	Drive washer	1
23	YS4330	Drive washer retainer	1
24	YS0425	Propeller washer	1
25	YS0830	Propeller nut set	2
26	YS7015	Piston	1
27	YS0615	Piston ring	1
28	YS6035	Wrist pin	1
29	YS1790	Rocker arm set	2
30	YS0560	Tappet adjusting screw set	2
31	YS0565	Tappet adjusting lock nuts	2
32	YS1800	Rocker arm shaft	1
33	YS1810	Rocker arm screw	1
34	YS0580	E ring set	2
35	YS0670	Cam gear	1
36	YS1820	Cam gear cover	1
37	YS1830	Cam gear cover O-ring	1
38	YS1840	Cam gear cover screws	2
39	YS0705	Cam gear bearing set	2
40	YS0675	Cam followers set	2
41	YS1850	Push rods	2
42	YS1860	Push rod covers	2
43	YS0690	Push rod cover O rings	4
44	YS6435	Con rod	1
	YS6440	Back plate assembly	
45	YS6445	Back plate	1
46	YS6450	Disc valve	1
47	YS6455	Disc valve pin	1
48	YS6460	Disc valve set screw	1
49	YS1930	Back plate gasket	1
50	YS6465	Carburetor body	1
51	YS6470	Throttle barrel	1
52	YS2050	Low speed needle valve	1
53	YS2060	Low speed needle valve O-	1
54	YS4315	Throttole barrel seal	1
55	YS1090	Throttle barrel retainer	1
56	YS0200	Throttle arm set	1
57	YS0785	Throttle stop screw	1
58	YS0790	Throttle stop spring	1
	YS6475	Needle valve set	
59	YS2690	Needle valve	1
60	YS2695	Needle valve O-ring	1
61	YS6480	Needle socket	1
62	YS6330	Needle socket O-ring	3
63	YS2710	Needle valve detent	1
64	YS1970	Carburetor gasket	1
65	YS5485	Carburetor screws	6
	YS6335	Regulator assembly	
66	YS5330	Regulator body A	1
67	YS5340	Diaphram	1
68	YS5395	Regulator valve	1
69	YS5345	Regulator valve O ring	1
70	YS6340	Regulator body B	1
71	YS6345	Regulator screws	2
72	YS6485	Regulator spacer	1
	YS0895	Exhaust pipe set	
	YS0405	Check valve	1
	YS6490	Gasket set	4
	YS6495	O ring set	11

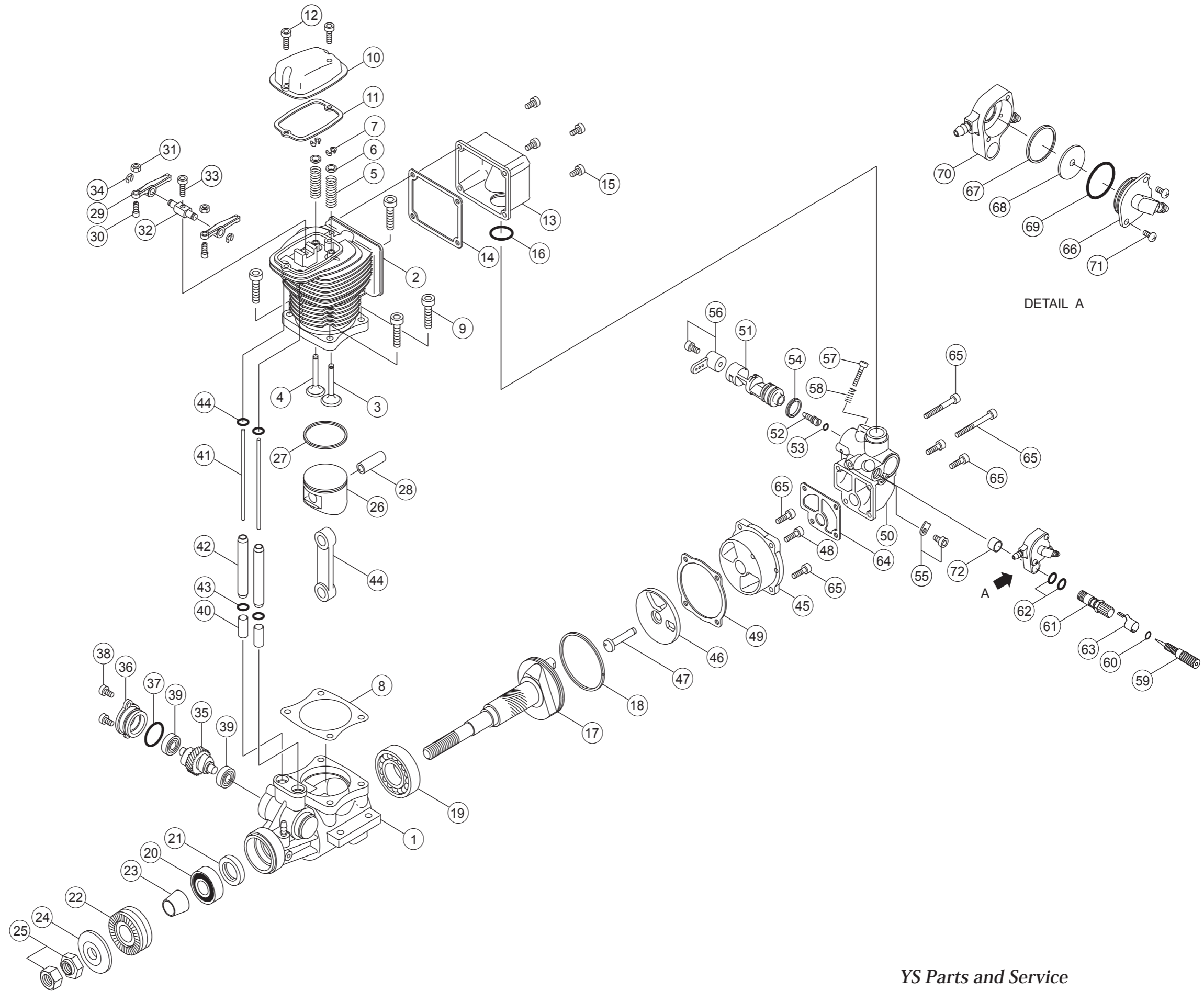

YS Parts and Service

1370 PORTER DRIVE MINDEN NEVADA 89423

Phone: 775-267-9252 Fax: 775-267-9690